

THIS DRAWING IS UNPUBLISHED. RELEASED FOR PUBLICATION  
 © COPYRIGHT - By - ALL RIGHTS RESERVED.

LOC	DIST	REVISIONS			
P	LTR	DESCRIPTION	DATE	DWN	APVD
AF	50	A2	REVISED PER ECR-11-006644	05APR11	HMR GJ

- CONTINUOUS STRIP ON REELS
- WIRE RANGE FOR NEW APPLICATIONS: 3.75–5.07mm<sup>2</sup>[7400–10,000CMA]  
(WIRE RANGE APPROVED FOR APPLICATIONS IMPLEMENTED PRIOR TO 2005: 4000–10,000 CMA).
- CRIMP WIDTH: 4.57[.180]F TYPE. CRIMP HEIGHT IN INCHES (+/- .002)=(TOTAL CMA OF WIRES + 20044)/288890.

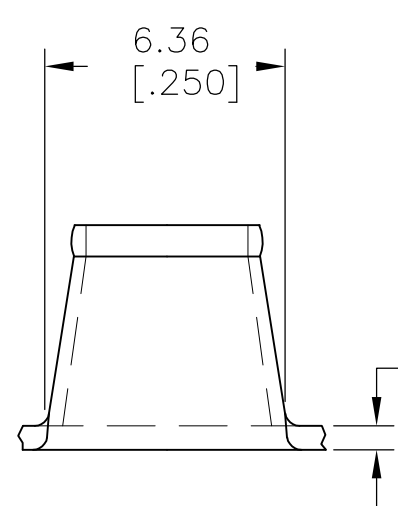
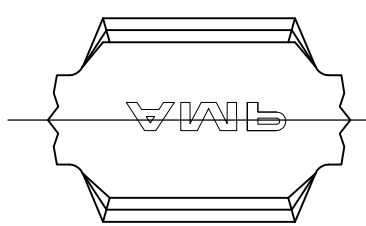

0.64±0.03  
[.025±.001]

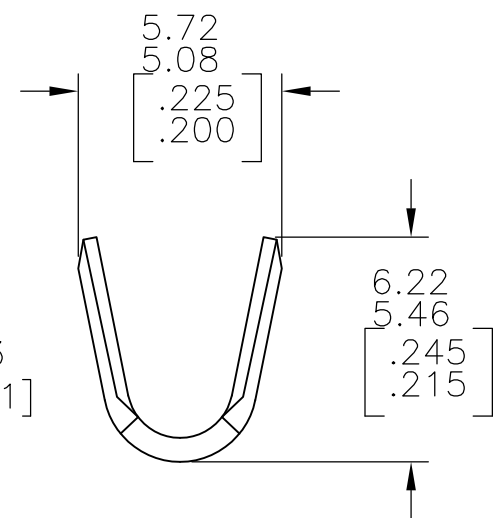

62357-1  
PART NO

THIS DRAWING IS A CONTROLLED DOCUMENT.		DWN jr_ruth	24NOV04	<b>STE</b> TE Connectivity	
DIMENSIONS: mm [INCHES]		CHK G PORTA	24NOV04		
TOLERANCES UNLESS OTHERWISE SPECIFIED:		APVD G PORTA	24NOV04	NAME	
0 PLC ± -		PRODUCT SPEC		SPLICE	
1 PLC ± -		APPLICATION SPEC			
2 PLC ± 0.25[.010]		114-2088		SIZE	CAGE CODE
3 PLC ± -		WEIGHT -		A3	00779
4 PLC ± -		CUSTOMER DRAWING		DRAWING NO	C-62357
ANGLES ± 5°		SCALE 1:1		SHEET	1 OF 1
MATERIAL TEMP 1 BTRASS	FINISH -	RESTRICTED TO -		REV	A2